

---

(19)  **Canadian  
Intellectual Property  
Office**

An Agency of  
Industry Canada

**Office de la Propriété  
Intellectuelle  
du Canada**

Un organisme  
d'industrie Canada

---

(11) **CA 509392** (13) **A**

(40) **25.01.1955**

---

(12)

(21) Application number: **509392D**

(51) Int. Cl:

(22) Date of filing: ..

---

(71) Applicant: **SARABER PETER.**

(72) Inventor: **SARABER PETER ().**

---

(54) **FLASHLIGHT LAMPS**

(57) **Abstract:**

(54) **LAMPES-ECLAIR**

*This First Page has been artificially created and is not part of the CIPO Official Publication*

509392

The invention refers to a flashlight-photography flash gun with folding reflector, especially for photographic exposures. Flashlight-photography/flash guns with folding reflectors are already known, in which the reflector consists of a number of separate parts. In such case, however, the reflector when folded, cannot remain attached to the flash gun. The preparation for use of these known flash guns consequently requires a relatively appreciable time. Furthermore, the conveyance of the two separate components, i.e. the flash gun and the reflector, is exceedingly inconvenient.

Contrary to these known flash guns with reflectors, the reflector in accordance with the present invention consists of such thin, elastic foil, e.g. sheet steel or sheet bronze, that it is easily rolled up and after unrolling automatically assumes its original form. This new roll-up reflector can be made in one piece and remain firmly attached to its flash gun even in its rolled condition.

The reflector is rolled up by drawing or alternatively pressing it down into the flash gun casing in such manner that when rolled up the reflector is housed inside the said casing.

The flash gun casing is suitably provided in one side with a slope acting as a guide in rolling up the reflector.

In accordance with a specific form of arrangement the withdrawal of the reflector into the flash gun casing is effected by means of an operating button or the like, connected with the reflector and movable in a guide slot in the casing.

The advantages of the flash gun in accordance with the invention are essentially the very simple and con-

A.]

sequently cheap construction, the instant readiness for use and the small dimensions of the reflector in the rolled-up state.

4 An additional advantageous feature according to the invention is that the displacement of the operating button in the guide slot of the flash gun casing not only serves to roll up or unroll the reflector but also enables the  
8 concavity of the reflector, i.e. its radius of curvature, to be adjustably varied.

The principle of the invention is applicable both to flash gun lamps of the type known by the Trade Mark  
12 "Vaku-Blitz" and to flash gun lamps of high-tension type, as well as to lamps working with flashlight powder.

The drawing represents an example of an arrangement according to the principle of the invention and shows  
16 further advantageous and novel features thereof. The drawing shows a flashlight-photography flash gun lamp of the "Vaku-Blitz" type.

Fig. 1 is a front view of the flashlight-photography  
20 flash gun comprising my invention shown fully assembled ready for use;

Fig. 2 is a side view of the flashlight-photography flash gun shown in Fig. 1;

24 Fig. 3 is a view similar to Fig. 2, but showing the reflector partially retracted preparatory to a folding operation;

Fig. 4 is a front view of the flashlight-photography  
28 flash gun shown in Fig. 3 and showing the partially retracted reflector;

Fig. 5 is a vertical sectional view through the fully-  
32 folded flashlight-photography flash gun with certain parts shown in elevation;

A

Fig. 6 is a rear view of the flashlight-photography flash gun showing the reflector fully rolled-up;

4 Fig. 7 is a transverse sectional view on line 7-7 of Fig. 2, illustrating the reflector fully opened and in use;

8 Fig. 8 is a transverse sectional view on line 8-8 of Fig. 3 showing the reflector partially folded;

8 Fig. 9 is a transverse sectional view on line 9-9 of Fig. 5 showing the reflector fully nested in the casing; and

12 Fig. 10 is a perspective view showing the co-action between the angularly disposed edges of the lamp casing and the angularly disposed edges of the reflector for facilitating the rolling and unrolling of the reflector with respect to the lamp casing as the reflector is moved  
16 longitudinally with respect to the lamp casing.

20 The flash gun consists of a barrel 1 with a lamp holder 2 receiving a lamp 3 of the "Vaku-Blitz" type, a base 4, an outer casing 6 and a reflector 8. One or more dry cells 5 can be accommodated in the usual manner in the barrel 1. The casing 6 surrounds the barrel 1 in such manner that an annular air gap 7 is left between the barrel 1 and the casing 6.

24 The reflector, which may be of other form than here shown, consists of a thin foil 8 of suitably resilient material, e.g., sheet steel or sheet bronze. The reflector 8 is provided with an operating button 9 movable  
28 in a longitudinally disposed guide slot 10 in the casing 6, in such manner that by moving the button 9 the reflector 8 can be drawn down into the air gap 7. By suitably forming the slop of edges 12 of the casing 6 on opposite  
32 sides of a central recess 15, the reflector 8 is caused to

roll up on itself when the edges 16 thereof are drawn  
down by the action of the button 9 against the edges 12  
of the casing which serve as lineally extending cams for  
4 guiding the reflector. The opposite sides of the upper  
peripheral edges of casing 6 are cut-away in a recess 15  
and are angularly inclined downwardly from positions  
spaced substantially more than  $180^{\circ}$  to a substantially  
8 V-shaped terminus rounded at the bottom of recess 15 in  
the top of the front of the casing facing forward in the  
direction of the light rays reflected by the reflector 8.  
The upper part 13 of the casing 6 and the lower part 11  
12 of the reflector 8 are suitably so shaped that the cur-  
vature of the reflector 8 in its highest position is only  
slight. The guide slot 10 is located in the rear of the  
casing extending from the upper part 13 of the casing to  
16 substantially the bottom of the casing. That is to say,  
the slot 10 is located in part of the wall section of  
maximum length. The edges 16 of the lower part 11 of  
the reflector 8 are formed on an angle with res-  
20 pect to the slope of edges 12 which is slightly obtuse, so  
that edges 12 and 16 coact to effect the rolling and un-  
rolling of the reflector 8 as button 9 is moved. The  
concavity or curvature of the reflector 8 can be adjusted  
24 at will by drawing down the operating button 9 more or  
less into the guide slot 10. By this means, curvatures  
of different radii can be obtained on the reflector 8,  
according to the conditions of exposure. The rectangular  
28 slot 14 in the base 4 serves for the attachment of the  
flash gun on a holder.

The embodiments of the invention in which an exclusive property or privilege is claimed are defined as follows:-

1. A flashlight-photography flash gun comprising a cylindrical barrel adapted to house current-storing and supplying means, a lamp holder at one end of said barrel adapted to support and hold a lamp externally of the latter, a cylindrical outer casing surrounding said barrel and spaced therefrom around the longitudinal external wall periphery thereof, said outer casing being partly cut-away at its end adjacent the lamp holder to provide a tapered guideway having opposite edges inclined to the longitudinal axis of the casing from positions spaced substantially more than  $180^{\circ}$  to a terminus in the front of the casing, said casing having a longitudinal slot in a part of its wall section of maximum length, a reflector of elastic metal foil housed in the space between the barrel and the outer casing, with its central longitudinal axis immediately adjacent said slot, said reflector having upwardly inclined opposite edges coacting with the inclined edges of said guideway, and a stud secured to said reflector on the longitudinal axis of the latter and protruding through said slot to the exterior of the outer casing for moving the reflector longitudinally from its housing to a position adjacent the lamp holder, and vice versa, said upwardly inclined edges of said reflector and the downwardly inclined edges of said guideway coacting through a camming action to control the unrolling and rolling-up of said reflector.

2. A flashlight-photography flash gun as set forth in claim 1, in which the downwardly inclined edges of said

[A]

tapered guideway and the upwardly inclined opposite edges of said reflector are related to each other by angles that are slightly obtuse.

3. A flashlight-photography flash gun as set forth in claim 1 in which the edges of the recess constituting the tapered guideway in the front of said casing intersect in a substantially V-shaped terminus.

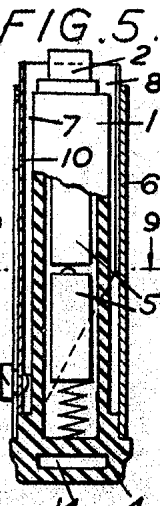
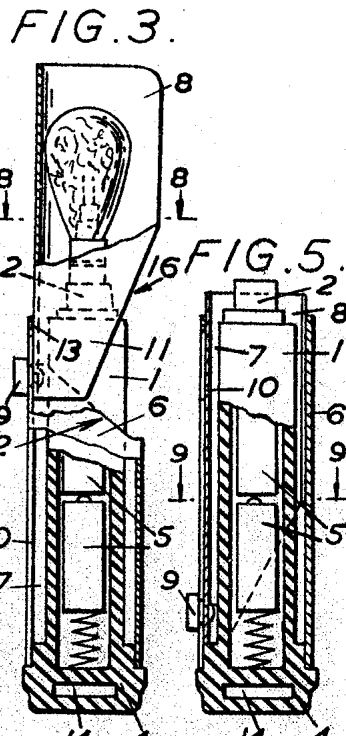
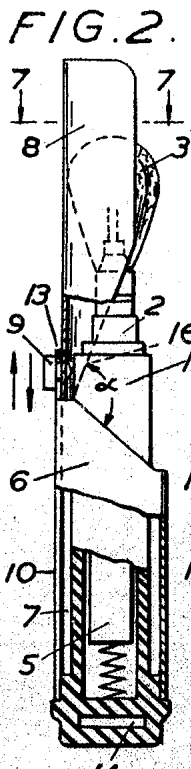
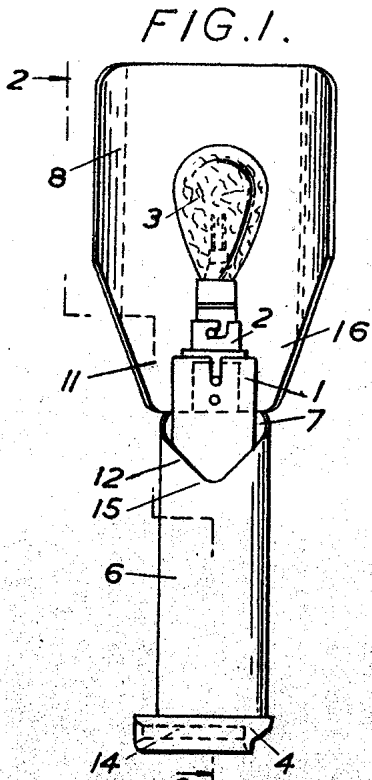

FIG. 4.

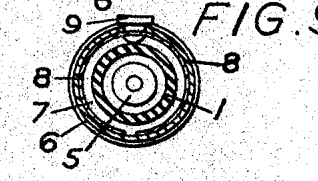
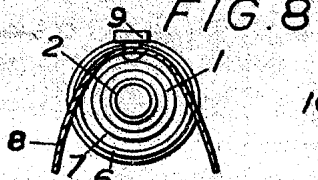
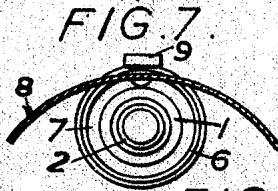
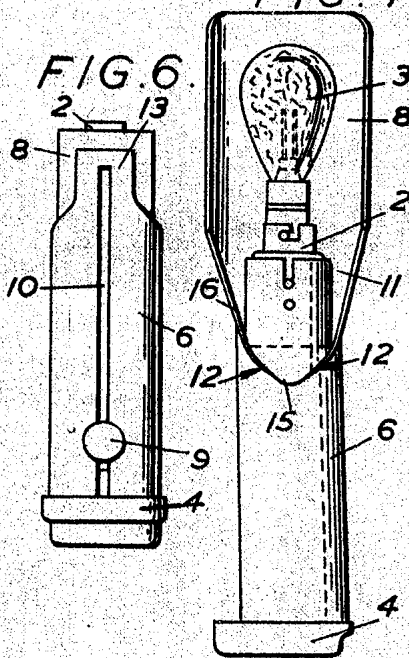
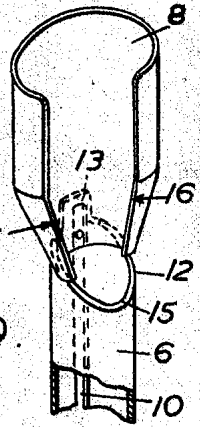

FIG. 10.



Inventor

PETER SARABER

By *Guthrie & Co.*  
Attys

A